



Rewarding Learning

ADVANCED (A2)

General Certificate of Education

2024

Centre Number

--	--	--	--	--

Candidate Number

--	--	--	--	--

Technology and Design

Assessment Unit A2 1

assessing

Systems and Control or
Product Design



ATE11

[ATE11]

TUESDAY 4 JUNE, AFTERNOON

TIME

2 hours.

INSTRUCTIONS TO CANDIDATES

Write your Centre Number and Candidate Number in the spaces provided at the top of this page and on the A3 pro forma answer pages provided.

Answer **both** questions in **either** Section A, B or C.

Answer to Questions **3(d)**, **4(c)**, **4(f)**, **5(h)** and **6(h)(i)** and **(ii)** should be made on the A3 pro forma answer pages provided.

At the conclusion of the examination, attach the A3 pro forma answer pages securely to this paper with the treasury tag supplied.

INFORMATION FOR CANDIDATES

The total mark for this paper is 80.

Quality of written communication will be assessed in Question **1(e)**, **3(c)(i)** and **5(f)**.

Figures in brackets printed down the right hand side of the pages indicate the marks awarded to each question or part question.

For Examiner's use only	
Question Number	Marks
1	
2	
3	
4	
5	
6	

Total Marks	
--------------------	--

Section A

Electronic and Microelectronic Control Systems

Answer **both** questions in this section.

- 1 (a) A number of sensing components are available to electronic designers. An example of one such component is the light dependent resistor (LDR) shown in **Fig. 1** along with its symbol.

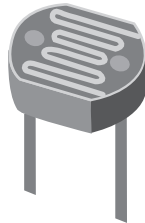

LDR

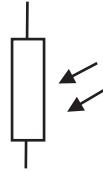

Symbol

Source: CCEA

Fig. 1

- (i) State how the resistance of the LDR shown in **Fig. 1** changes as light level decreases.

_____ [1]

- (ii) **Fig. 2** below shows a circuit diagram for a voltage divider circuit that incorporates the LDR from **Fig. 1**. Sketch a graph on the axes provided to show how the output of the voltage divider V_o , varies as the light level increases.

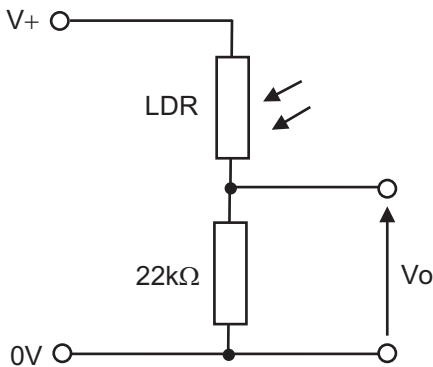

Circuit diagram

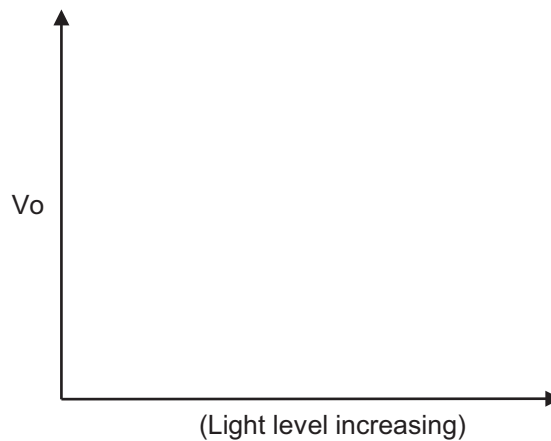

Graph

Source: CCEA

Fig. 2

[2]

Examiner Only	
Marks	Remark

- (iii) Calculate the output voltage range for the voltage divider shown in **Fig. 2** if the supply voltage is 5 V and the resistance range of the LDR is 1 k Ω to 500 k Ω .

Candidates need to show their working out in the space below.

Range _____ [3]

Examiner Only	
Marks	Remark

- (b) Part of a design for a fluid flow meter is shown in **Fig. 3**. A rotating turbine shaft has an attached disc with two slots.

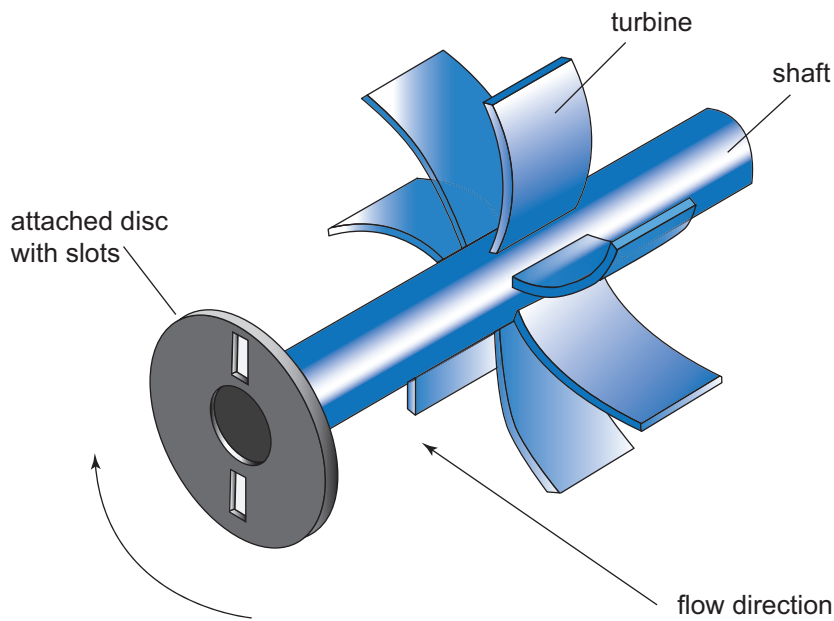

Fig. 3

Source: CCEA

- (i) Show with the aid of a labelled sketch how an LDR could be used as part of an arrangement to detect the revolutions of the disc shown in **Fig. 3**.

[2]

- (ii) Explain **one** potential limitation of utilising an LDR as a method of sensing the slots in the rotating disc in **Fig. 3**. Then suggest an alternative method that would overcome this limitation.

Explanation _____

_____ [2]

Alternative _____ [1]

Examiner Only	
Marks	Remark

(c) Fig. 4 shows a systems diagram showing how pulses, which are generated from the rotating disc in Fig. 3 are to be counted in order to provide an indication of fluid speed. The pulses from the rotating disc are counted for a period of 10 seconds before being displayed. A frequency divider is utilised to ensure that the number displayed represents the actual fluid speed.

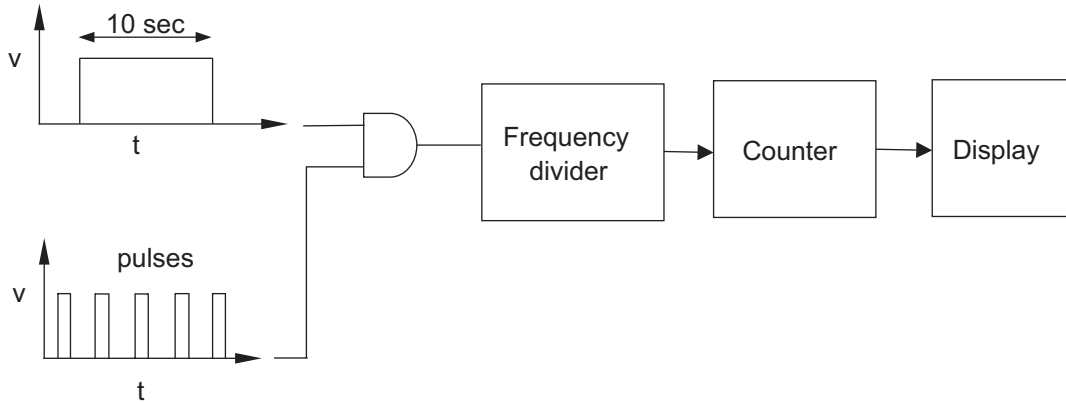

Source: CCEA

Fig. 4

- (i) Explain the function of the AND gate in the system shown in Fig. 4.

[2]

- (ii) During initial tests on the flow meter in Fig. 3 it was found that the disc rotated at 3 revolutions per second when the fluid flow rate was 20 metres per second.

Determine the number of pulses generated in the 10 second time period for a fluid flow rate of 20 metres per second. Then calculate the factor this number must be divided by to display the fluid flow rate in metres per second.

Candidates need to show their working out in the space below.

Division factor _____ [3]

Examiner Only	
Marks	Remark

- (d) The frequency divider in **Fig. 4** is based on a binary counter as shown in **Fig. 5** below. The reset pin of the counter is negative edge triggered and the output pin QA is the least significant bit.

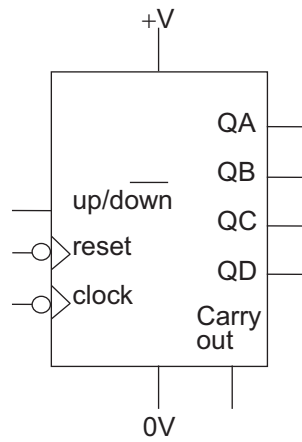

Source: CCEA

Fig. 5

- (i) Explain what is meant by the term negative edge triggered when referring to the reset pin of the counter in **Fig. 5**.

[2]

- (ii) Show on **Fig. 5** how the binary counter can be used as a frequency divider to provide the calculated division factor from **1(c)(ii)**. [3]

- (e) A strain gauge is a commonly utilised sensor to measure deformation (bending or twisting) in metal beams. Describe **two** main characteristics of strain gauges that make them suitable for this purpose. Then explain why a Wheatstone bridge would be used in conjunction with a strain gauge. Finally, discuss the issues associated with temperature variations that occur while testing using strain gauges.

Examiner Only	
Marks	Remark

- (f) **Fig. 6** shows a systems diagram for a prototype design to alert when the flow rate in an industrial process becomes dangerously high. The system measures the duration (T) of input pulses from a fluid flow sensor. If the duration of the pulse is over or under a specific value an appropriate visual/audible output is produced.

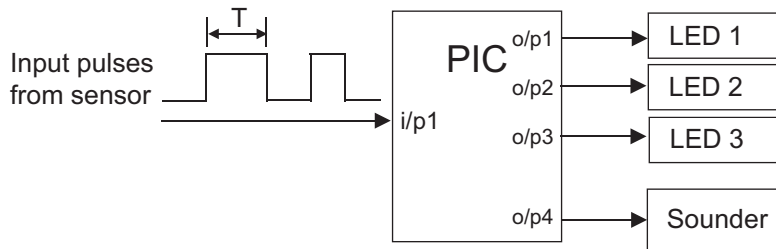

Source: CCEA

Fig. 6

Draw an annotated circuit diagram with associated flow chart program (on the following pages) for the system shown in **Fig. 6**. Your answer should meet the following specification points:

- Measure the duration of an input pulse to the nearest 0.01 second.
- Check the duration of the input pulses once every 5 seconds.
- Illuminate a green LED (LED 1) if the pulse duration is 0.4 seconds or greater.
- Illuminate an amber LED (LED 2) if the pulse duration is less than 0.4 seconds but greater than 0.2 seconds.
- Cause a 12 volt sounder to turn on and off and a red LED to flash if the pulse duration is 0.2 seconds or less.
- Incorporate a hardwired mute switch for the sounder.

[10]

Examiner Only	
Marks	Remark

Answer pages Question 1(f)

Answer pages Question 1(f)

- 2 (a) A seven segment display (LED) is shown along with its circuit symbol in Fig. 7.

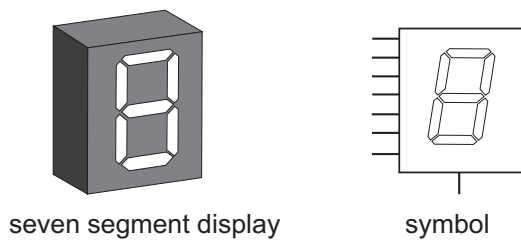

Source: CCEA

Fig. 7

- (i) The seven segment display in Fig. 7 is a common cathode type with each segment containing a single LED. Show with the aid of a circuit diagram how the common cathode LEDs are connected in the display.

[2]

- (ii) Excluding cost considerations, explain **one** advantage of using an LED type display over a liquid crystal display (LCD) when designing an electronic system.

[2]

Examiner Only

Marks Remark

- (b) **Fig. 8** shows a prototype PIC based circuit designed to indicate one of three speeds that have been selected on a fan heater. The three position multipole switch is operated when a speed has been selected and the corresponding number will then be displayed, e.g. when the switch is in position i1 the display will show the number 1.

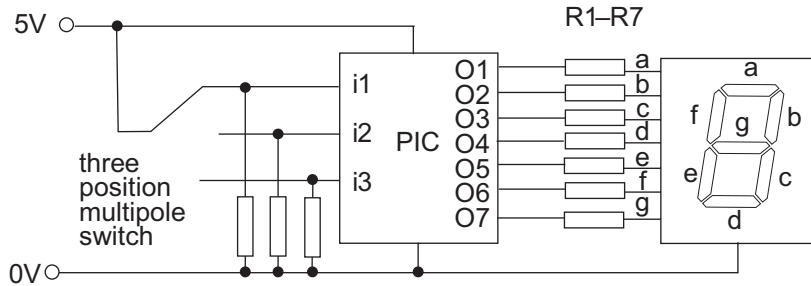

Source: CCEA

Fig. 8

- (i) Each segment of the seven segment display in **Fig. 8** contains two LEDs in series with each operating at a forward voltage of 1.8 volts and a maximum current of 10 mA. Calculate the value for a protective resistor required for one segment if the output voltage from the PIC is 5V.

Candidates need to show their working out in the space below.

Answer _____ Ohms [2]

- (ii) Determine the total power in mW dissipated by the calculated protective resistors in **Fig. 8** when the number 2 is displayed.

Candidates need to show their working out in the space below.

Answer _____ mW [3]

Examiner Only	
Marks	Remark

- (iii) Using the minimum number of flowchart commands, complete the program below to display the appropriate fan speed number depending on the position of the multipole switch. In your flowchart you must indicate which PIC outputs are operated for each switch position.

START

[5]

- (c) The PIC based fan speed indicator circuit in Fig. 8 is to be replaced by a hard wired based circuit as shown in Fig. 9. In this circuit the PIC has been replaced by logic gates and a seven segment decoder.

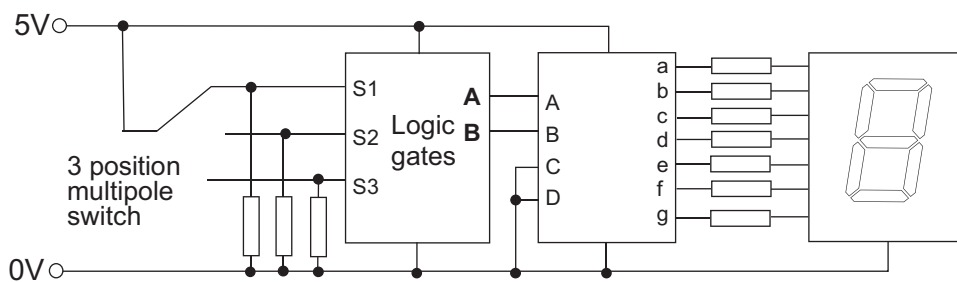

Source: CCEA

Fig. 9

- (i) Explain the specific purpose of the seven segment decoder in Fig. 9.

[2]

Examiner Only	
Marks	Remark

- (ii) Complete the truth table in **Fig. 10** for the logic circuit shown in **Fig. 9** to provide the appropriate outputs (**A** and **B**) for the three different switch positions. (**S1**, **S2** and **S3**)

S1	S2	S3	A	B

[3]

Fig. 10

Fig. 11 shows completed Karnaugh maps for **A** and **B** in Fig. 10.

	$\overline{S1}$ $\overline{S2}$	$\overline{S1}$ S2	S1 S2	S1 $\overline{S2}$
$\overline{S3}$	0	0	0	1
S3	1	0	0	0

Output A

	$\overline{S1}$ $\overline{S2}$	$\overline{S1}$ S2	S1 S2	S1 $\overline{S2}$
$\overline{S3}$	0	1	0	0
S3	1	0	0	0

Output B

Fig. 11

- (iii) Explain why minimisation is not applicable in the Karnaugh maps for either **A** or **B** in Fig. 11.

[2]

- (iv) Write logic expressions for **A** and **B**.

Logic expression for A _____

Logic expression for B _____ [2]

- (v) Draw the complete logic circuit required for **Fig. 9** that will provide the required inputs, **A** and **B**, for the seven segment decoder in order to display the three fan speeds as selected by the switch.

[3]

Examiner Only	
Marks	Remark

(vi) Explain **one** disadvantage of opting for the hard wired solution shown in **Fig. 9** rather than a PIC based solution for the fan speed indicator shown in **Fig. 8**.

[2]

(d) **Fig. 12** shows a rotary potentiometer, LED bar array display and a buzzer. The display and buzzer are to be utilised in a system to show small adjustments to the potentiometer and provide an audible warning.

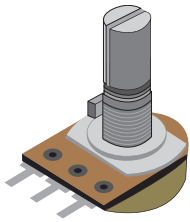

rotary potentiometer

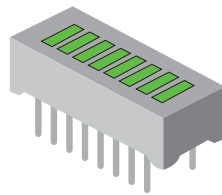

LED bar array display



buzzer

Source: CCEA

Fig. 12

(i) When the potentiometer in **Fig. 12** is connected to a power supply the voltage from it will range from 0–0.8 volts while a bar array driver requires a 0–5 volt input range in order to drive the bar array. An amplifier based on an op-amp is required to achieve this. Calculate the required gain for the amplifier.

Candidates need to show their working out in the space below.

Answer _____ [2]

(ii) On the following pages, draw an annotated hard wired circuit diagram for a complete system that fulfils the following requirements:

- A suitable dual power supply amplifier based on an op-amp that will sense the adjustment of the rotary potentiometer.
- Drive an 8 bar common anode bar array display.
- When the top bar of the bar array is illuminated a buzzer will continuously sound on and off at a frequency of 1 Hz until the top bar is no longer illuminated.
- Appropriate component values to achieve the required gain for the bar array driver and the frequency of the buzzer output.

[10]

Examiner Only	
Marks	Remark

Answer pages question 2(d)(ii)

Answer pages question 2(d)(ii)

Section B

Mechanical and Pneumatic Control Systems

Answer **both** questions in this section.

- 3 (a) (i) SAE and viscosity are terms associated with oils.

Briefly outline what the acronym SAE means.

[1]

Explain what is meant by viscosity in relation to oil.

[2]

Examiner Only

Marks Remark

- (ii) Ratchet and pawl mechanisms are often used in lifting equipment. Using an annotated sketch, outline the main features of a ratchet and pawl mechanism and briefly explain its function.

[3]

Function

 [1]

- (iii) Briefly explain **three** of the main functions of oil in a mechanical system such as a car engine.

1. _____

 [1]

2. _____

 [1]

3. _____

 [1]

Examiner Only	
Marks	Remark

- (ii) In a warehouse, cylinders A1 and A2 shown below in **Fig. 14** are used to operate a door. These cylinders are supplied with an air pressure of 0.4 N/mm^2 and are identical, each having a cylinder diameter of 35 mm . It is intended to replace cylinders A1 and A2 with a single cylinder (cylinder B) that produces the same overall outstroke force when operated at the same air pressure.

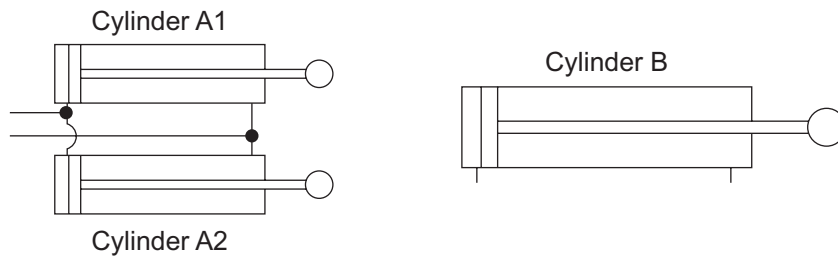

Source: CCEA

Fig. 14

Calculate the cylinder outstroke force and the diameter of cylinder B.

Assume $\pi = 3.14$ and ignore friction.

Candidates need to show their working out in the space below.

Outstroke force _____ N [2]

Diameter of cylinder B _____ mm [1]

Examiner Only	
Marks	Remark

- (ii) Braking mechanisms are an important part of many mechanical systems. Using an annotated sketch, outline the main features of a **disc brake** mechanism and explain its method of activation.

Examiner Only

Marks Remark

[3]

Method of activation _____

_____ [2]

- (d) An online retailer wishes to fit central locking systems on the rear shutter doors of their delivery trucks so that the contents of the lorry can be secured when left unattended for short periods. The central locking is powered by a pneumatic cylinder mounted in the door frame of the lorry as shown in **Fig. 15** which operates a locking bar to lock the rear shutter door.

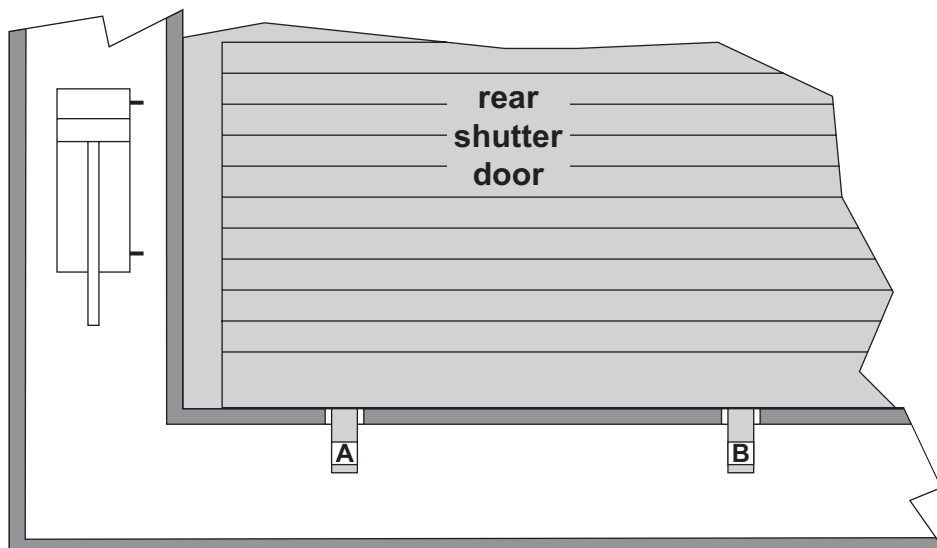

Source: CCEA

Fig. 15

- Using the A3 pro forma provided (answer number **3(d)**), in the space inside the door frame, design, draw and annotate a solution using linkages and mechanisms that will use the motion of the pneumatic cylinder to operate locking bars that pass through points **A and B** so that the shutter door can be locked and unlocked. [10]

- 4 (a) (i) A conveyor belt system in the warehouse uses self-aligning bearings. Using an annotated sketch, outline the main features of a self-aligning bearing.

[3]

- (ii) State **one** reason why a self-aligning bearing would be used in a mechanical system.

_____ [1]

- (b) Calculate the volume of air consumed in litres per minute by the double acting cylinder shown in **Fig. 16** if it completes 2 return cycles in 10 seconds.

$D = 4 \text{ cm}$

$S = 5 \text{ cm}$

$d = 2 \text{ cm}$

Gauge pressure = 5.5

Atmospheric pressure = 1.25

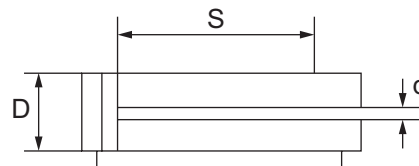

(drawing not to scale)

Source: CCEA

Fig. 16

Assume $\pi = 3.14$ and ignore friction.

Candidates need to show their working out in the space below.

Answer _____ litres per minute [4]

Examiner Only	
Marks	Remark

- (c) A large online retailer uses a range of pneumatic and mechanical systems to select, sort and transport orders from warehouse stock for delivery to customers.

Complete the following sequence on the A3 pro forma (answer number **4(c)**) using the minimum number of groups in order to produce this system. Some of the piping has been completed on the pro forma to assist you. The sequence begins:

- By closing guards, A and B and C, this will activate the circuit sending cylinder A positive.
- When Cylinder A is positive it will send Cylinder B positive.
- When Cylinder B goes positive it is detected by a 3/2 valve which sends Cylinder B negative.
- When Cylinder B goes negative it is detected by a 3/2 valve which sends Cylinder C positive after a short time delay.
- When Cylinder C goes positive it is detected by a 3/2 valve which sends Cylinder C negative.
- When Cylinder C goes negative it sends Cylinder D positive.
- When Cylinder D goes positive it is detected by an air bleed which sends Cylinder A negative.
- When Cylinder A goes negative it is detected by a 3/2 valve which sends Cylinder D negative. [10]

- (d) (i) A new crane is to be fitted in the warehouse of the online retailer. This crane has a prototype mechanical drive train shown in **Fig. 17** which is used to drive the movement of the crane. If gear A is rotating in an anti-clockwise direction, state the direction of rotation of gear M.

Answer _____ [1]

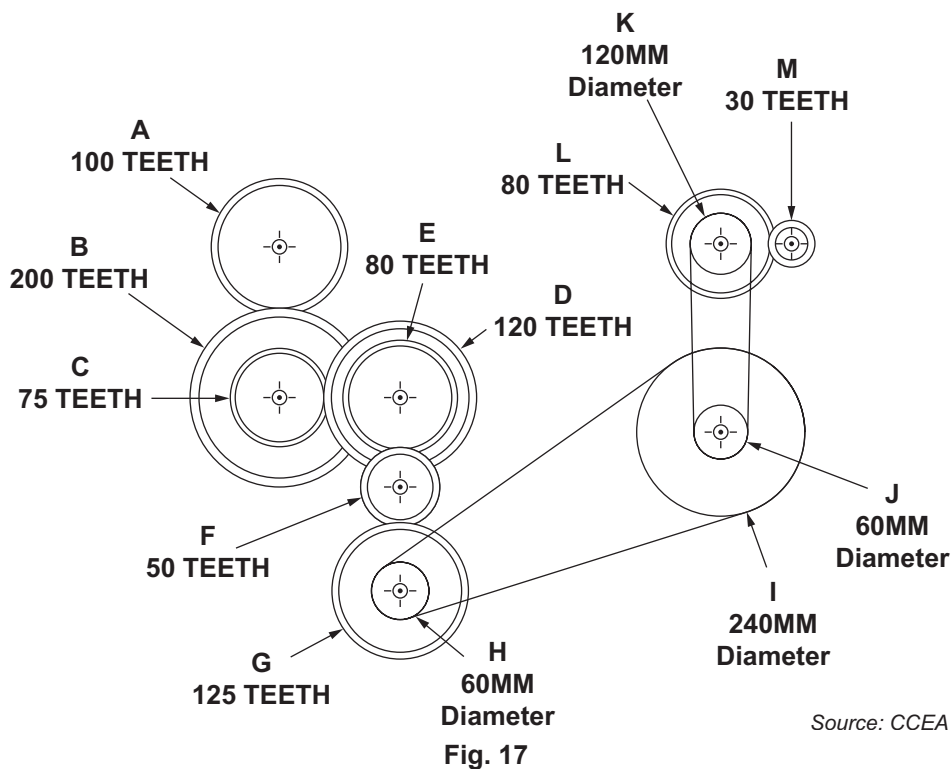

Examiner Only	
Marks	Remark

(e) Cams are commonly used in mechanical systems. **Fig. 18** shows a blank performance / displacement diagram. Complete the performance / displacement diagram using appropriate drawing techniques to show the following:

- $0^\circ - 120^\circ$ 60 mm rise with uniform acceleration and retardation.
- $120^\circ - 150^\circ$ dwell.
- $150^\circ - 300^\circ$ 40 mm fall with simple harmonic motion.
- $300^\circ - 360^\circ$ 20 mm fall with uniform motion.

[4]

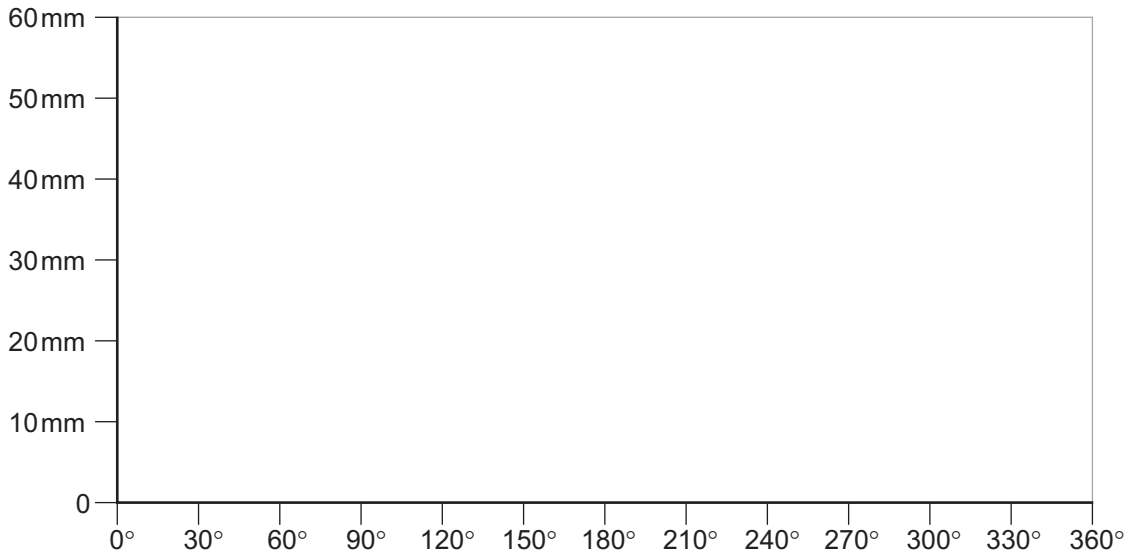

Source: CCEA

Fig. 18

(f) The online retailer handles large amounts of packages and parcels in a distribution centre. The loading dock shown in **Fig. 19** must accommodate a range of delivery vehicles so the angle of the loading ramp must be adjustable to allow forklift access.

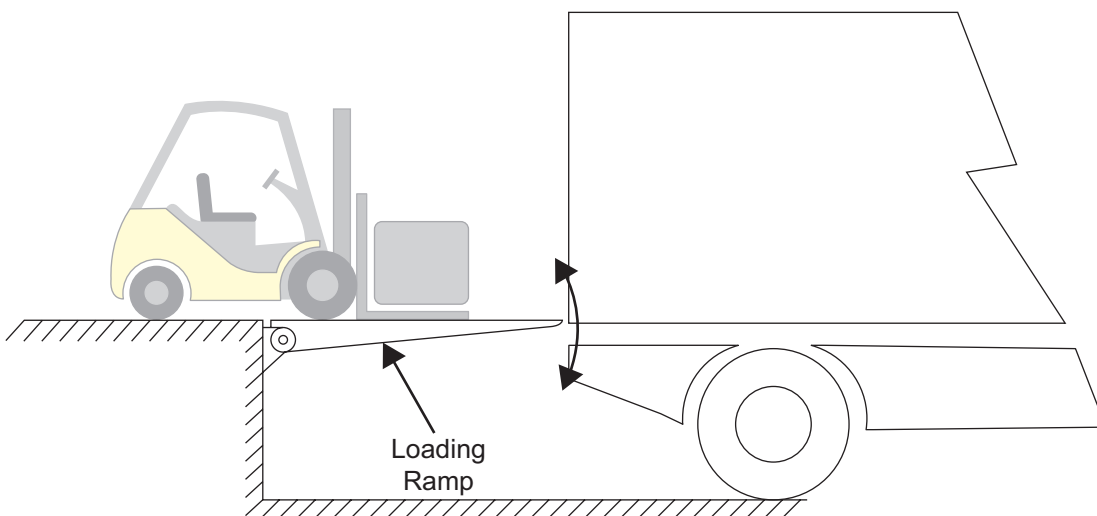

Source: CCEA

Fig. 19

Examiner Only	
Marks	Remark

Using the A3 pro forma provided (answer number **4(f)**) design, draw and annotate a solution that will enable the angle of the loading dock ramp to be adjusted using a mechanical system. The mechanical system is to be operated by means of a hand wheel which when turned will adjust the angle of the loading ramp. [10]

Examiner Only	
Marks	Remark

Section C

Product Design

Answer **both** questions in this section.

- 5 **Fig. 20** shows a photograph of a handheld measuring wheel designed and manufactured by a company as part of a wide range of measuring devices.



Source: Principal Examiner

Fig. 20

- (a) Some designers may consider the handheld measuring wheel to be an incremental product.

With reference to a different but suitable product of your choice, explain what is meant by an incremental product.

[2]

Examiner Only	
Marks	Remark

- (b) (i) The company designing and manufacturing the handheld measuring wheel has completed an environmental audit.

Explain what is meant by an environmental audit.

[2]

- (ii) Outline **one** reason why it would be beneficial for the company producing the handheld measuring wheel to have complied with an environmental audit.

[1]

- (c) When designing the handheld measuring wheel, the company considered the issues regarding sustainability in the manufacture of plastics.

Explain **one** main issue regarding sustainability in the manufacture of plastics.

[2]

Examiner Only

Marks Remark

(h) During consumer trials of the measuring wheel shown in **Fig. 21**, feedback suggested that the company should produce a bracket which will allow the user to attach a mobile phone in order to capture a recording or image of the display.

Using the blank A3 pro forma (answer number **5(h)**), use detailed annotated sketches to produce **one** possible solution for the following:

A suitable design that will allow the user to quickly and securely attach a mobile phone, with measurements of approximately 70 mm × 150 mm × 8 mm, to the plastic tubing at position X–X on **Fig. 21**. Your design should allow the user to quickly adjust the angle of the phone to facilitate a recording or an image of the display.

Explain how your design could minimise the use of materials and manufacturing processes.

[10]

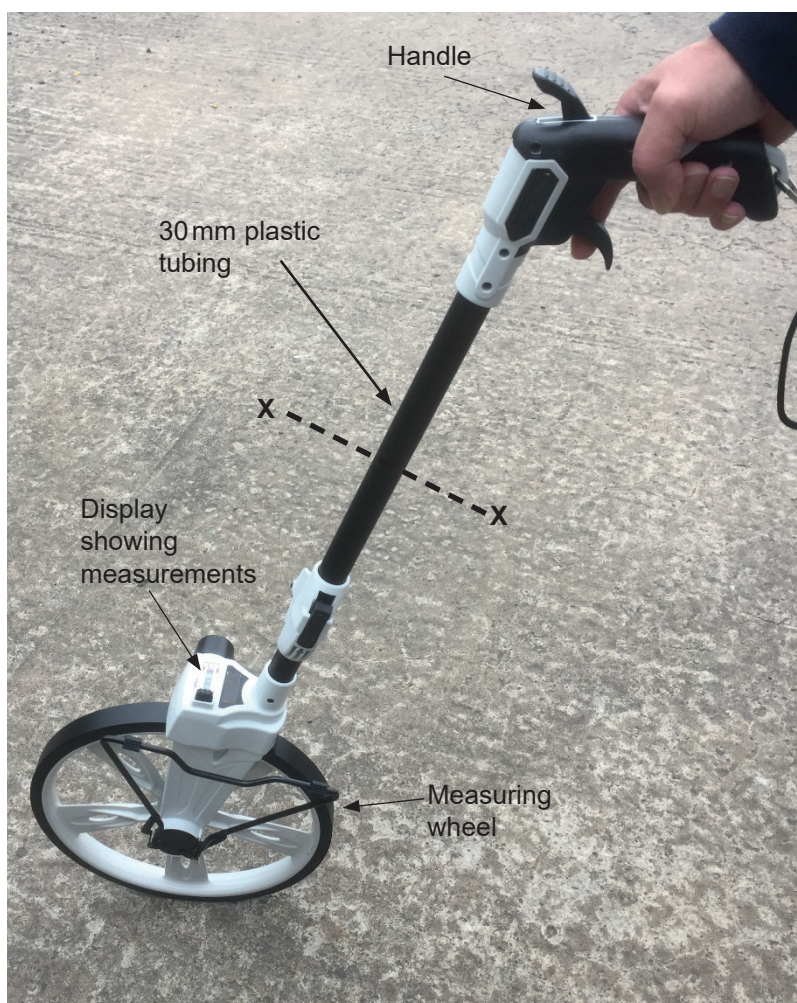

Source: CCEA

Fig. 21

Examiner Only	
Marks	Remark

BLANK PAGE

(Questions continue overleaf)

(ii) Using a different example describe a product which incorporates cultural factors in its design.

[2]

(h) Fig. 23 below shows photographs of the drone and its accessories together with a table containing dimensions of the parts to be packaged.



Part	Dimensions
Drone	Width 80 mm Length 180 mm Depth 80 mm
Controller	Width 120 mm Length 150 mm Depth 40 mm
Package of 4 batteries	Width 50 mm Length 60 mm Depth 10 mm
Manual	Width 120 mm Length 100 mm Depth 5 mm

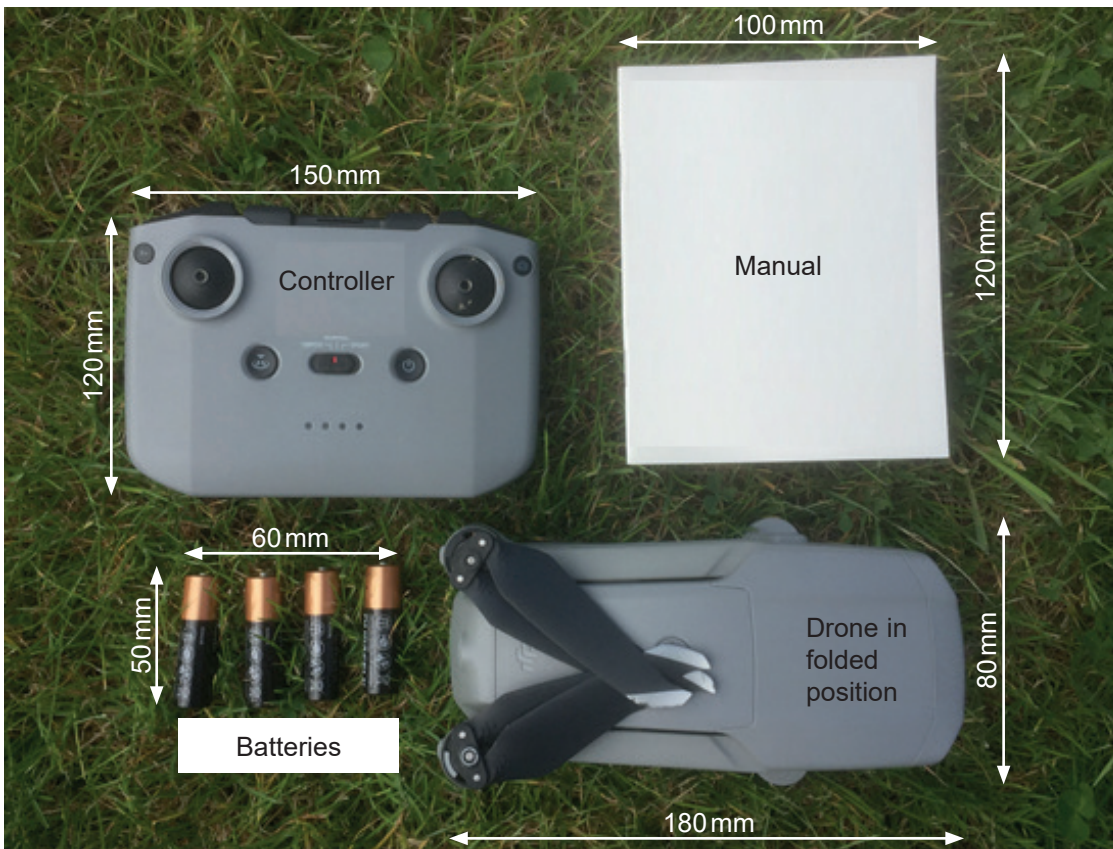

Source: CCEA

Fig. 23

Examiner Only	
Marks	Remark

On the blank A3 pro forma provided (answer number **6(h)(i) & (ii)**), produce **one** suitable solution for each of the following:

- (i) An annotated sketch of an innovative and appealing A5 sized design which could be used for the front of the packaging. This would communicate to the customer the following product information:
1. The drone should not be flown at a height exceeding 100 metres. [2]
 2. Flying time on fully charged batteries should not exceed 30 minutes. [2]
- (ii) Detailed annotated sketches of an appropriate design of packaging, which minimises materials and space required for the drone and the accessories shown in **Fig. 23**. The design should provide suitable protection to the contents. In the design of the packaging, consideration should be given to dimensions and minimising manufacturing processes. [6]

Examiner Only	
Marks	Remark

THIS IS THE END OF THE QUESTION PAPER

Permission to reproduce all copyright material has been applied for.
In some cases, efforts to contact copyright holders may have been unsuccessful and CCEA
will be happy to rectify any omissions of acknowledgement in future if notified.

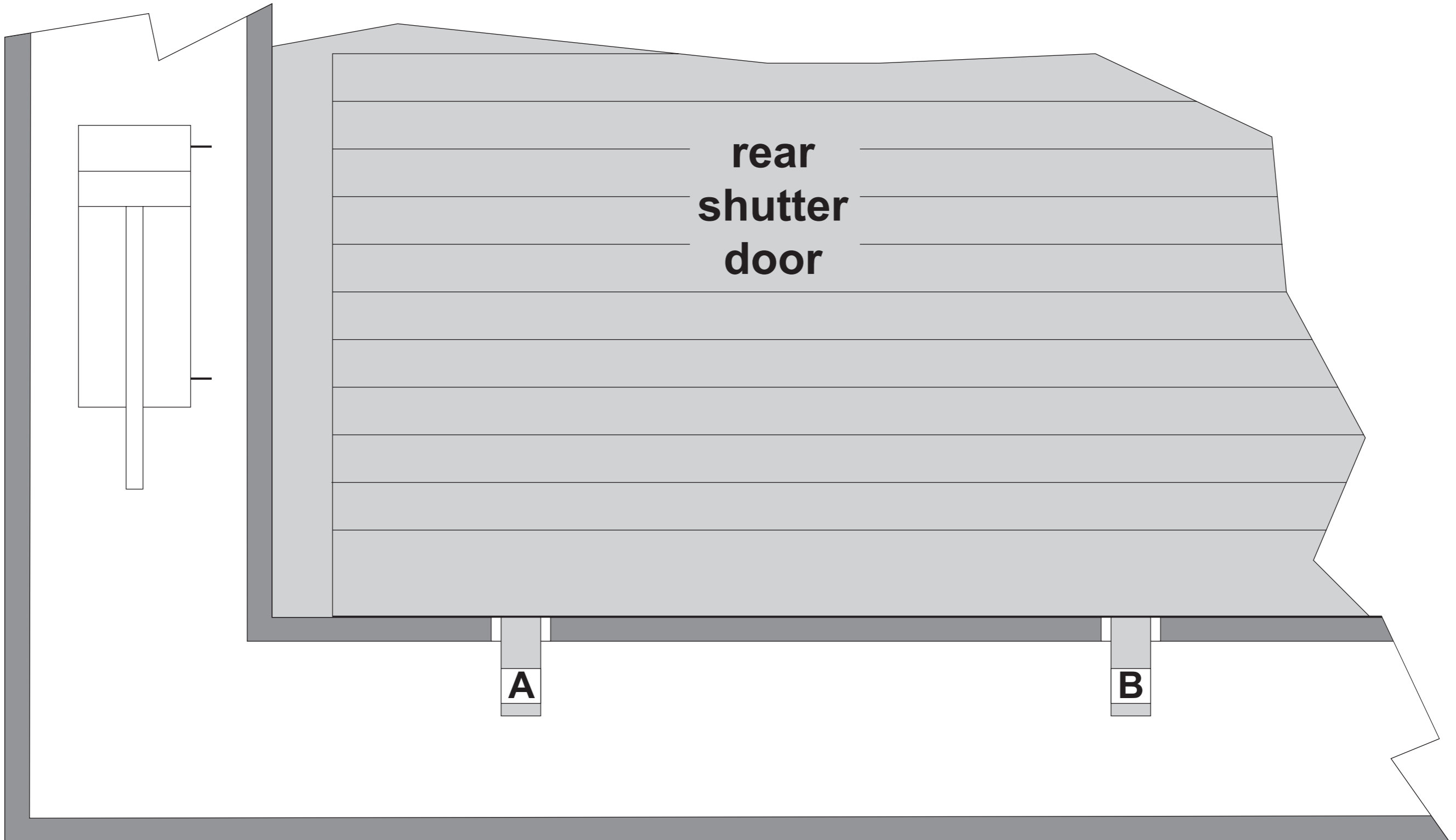

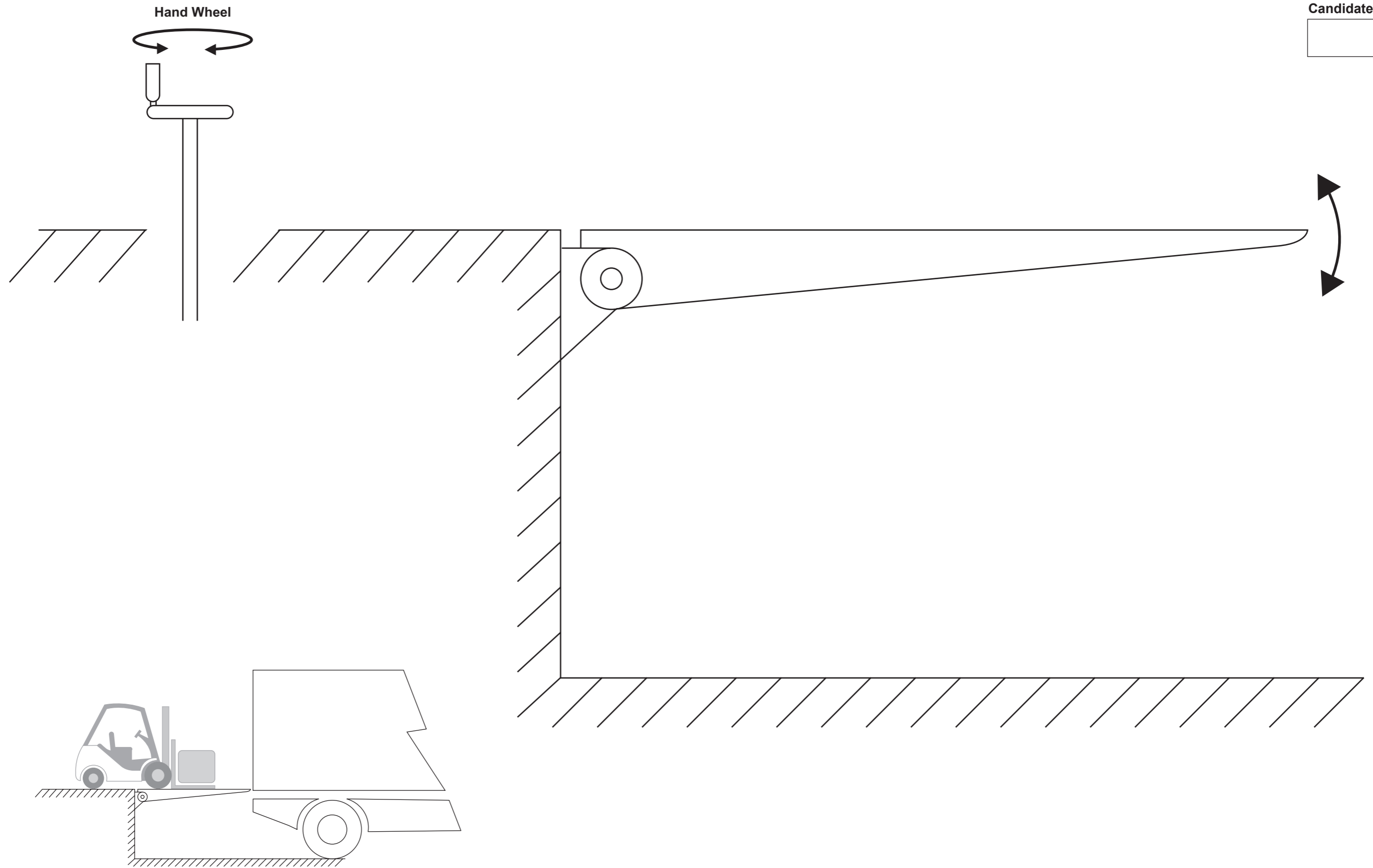

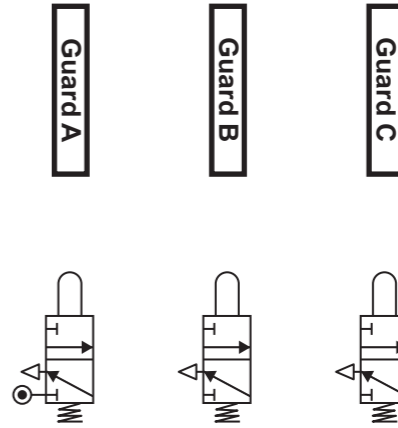
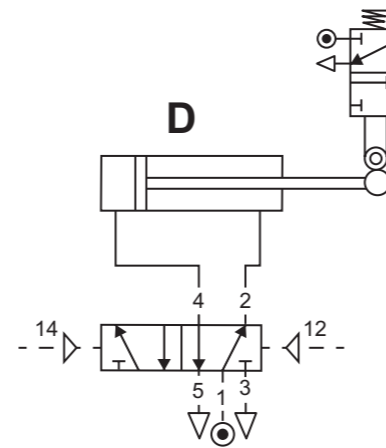
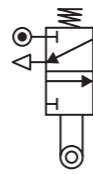
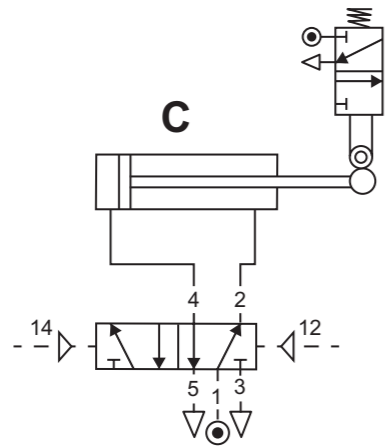
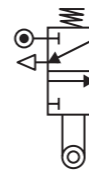
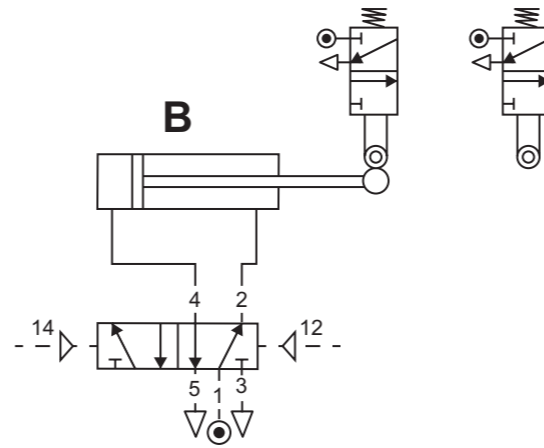
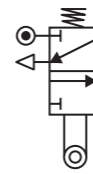
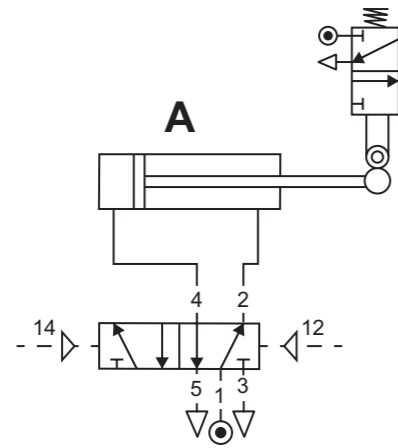

- Group 4
- Group 3
- Group 2
- Group 1

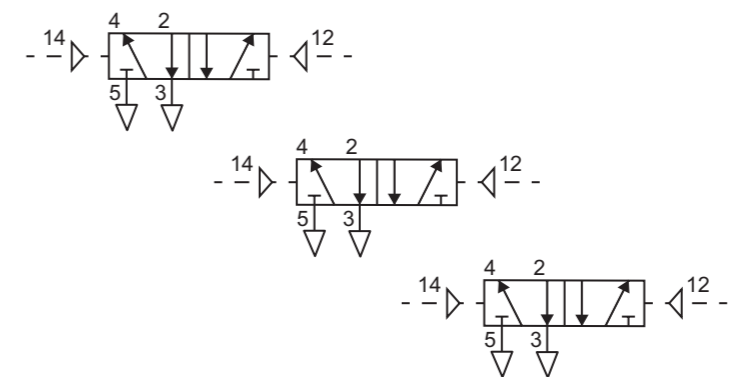

Centre Number

71	
----	--

Candidate Number

--

**Pro forma answer page
(answer number 6(h)(i) & (ii))**

**Advanced (A2) Technology and Design
Assessment Unit A2 1 Summer 2024**

Centre Number

71	
----	--

Candidate Number

--

